

MAXIMUM LEVEL SENSOR

UNIVERSAL VIBRATION LIMIT SWITCH FOR FINE GRAINED BULK MATERIALS.



**For dust explosion
imperiled areas on
application**

This vibration limit switch is a robust fill level sensor for silos with grained or dusty bulk cargos, even if they have a very low piled weight. The different construction designs allow various areas of application, also in dangerous dust explosion areas of the zone 20 or in foodstuffs.

Areas of Application

- No compensation, fast and low-cost start of operation.
- Non-sensitive to crust building, maintenance-free operation.
- No mechanically moved parts, no abrasion, long durability.
- Various electronic applications, optimal adaptation into the system control.
- Body with clear cover, switching status display recognizable from outside, easy to control.
- Aluminum body with separated connection space, also for protection model EEx de
- Plastic, high-grade steel 1.4571 or aluminum.

Details / Explanation

Body Finish

Installation

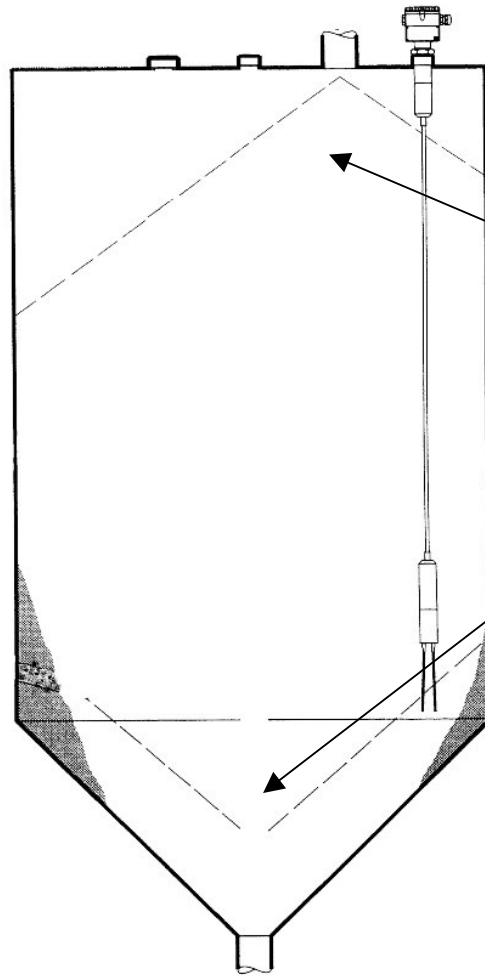

When calculating the necessary cord length, the angle of driving slope of the angle of repose or the haul-off hopper have to be considered.

To keep the tensile load low, the installation is done next to the silo barrier, but not too close, so that the sensor does not hit the wall if it swings.

Functioning

The symmetrical swing fork is stimulated on its resonance frequency. If it dives into bulk cargo, the swing character changes, and the electronic activates either an electronic switch or a relays. On top of the swing fork the vibrating limit switch is extremely sensitive which allows a minimum detection level in bulk materials with very low plied density. At the swing fork root however, the vibrating limit switch is non-sensitive, as a result crust building on the container wall does not influence the proper function. The vibrating limit switch can be operated in minimum or maximum standby current protection, which means when reaching the minimal or maximal fill level, filling errors or power failure the electronic switch locks up or the relay drops down.

Technical Data

Vibration limit switch	
Functioning	Absorbing of the swinging of a self-resonance swinging oscillating fork.
System structure	Complete fill level limit switch, consisting of measuring type probe with pre-installed electronic application (switch gear).
Signal processing	Two-wire-alternating current specification. Switching the demand over a thyristor directly in the supply unit electric system. Three-wire-continuous current specification. Switching the demand over a transistor and a separate connection. All current specification with relay output. Switching the demand over a potential-free change-over contact.
Galvanic isolation	Between measuring sensor and emergency current
Measured variable, metering range	Filling level (threshold, binary), given through length of the probe (rope) given (circa. 800 ...20000 mm from top).
Output signal	Binary; when reaching the threshold outlet blocked.
Safety switch	Minimum – or maximum – standby current security, switchable.
Response time	Ca.0,5 s at covering, ca.1,5 s at release. Switchable to ca. 2,5 s at covering, ca.7,5 s at release.
Precision of measurements at a temperature T =20 °C, operating pressure p =1 bar, piled density of the bulk material >1 kg/l, grain size <2 mm	Error of measurement: Ca.10 mm at vertical installation, 5mm at sideways installation of the probe. Settling time: After activating the emergency current the outlet keeps blocked for ca. 2,5 s. Response time variation: +/- 25 % at covering or release. Influences of temperature and operating pressure: insignificant.
Ambient temperature	-40 °C ...+70 °C
Type of protection (body)	IP 66 after DIN 40050
Temperature of measuring material	-40 °C ...+150 °C
Piled density of measuring material	min.20 g/l
Grain size of measuring material	up to 10 mm
Process connections	Conical thread R 1 ½ after DIN 2999 part 1.
Electronic connection	Screw clamps on the electronic application for maximum 2,5 mm ² cord. In end splice A 2,5 -7 after DIN 46228. Screw clamps in a separate connection space for aluminum bodies with plastic coating. For max.2,5 mm ² cord in end splice A 2,5 -7 after DIN 46228.
Operation display surface	Rotary switch for change-over of the minimum and maximum safety switching. Red illuminating diode for displaying the status.

Article number

Vibration limit switch	
	Article number
	731 10 047

MAXIMUM LEVEL SENSOR

CAPACITIVE LIMIT LEVEL DETECTION COMPACT FILLING LEVEL LIMIT SENSOR WITH INTEGRATED ACTIVE OUTLET COMPENSATION.

For dust explosion
imperiled areas on
application

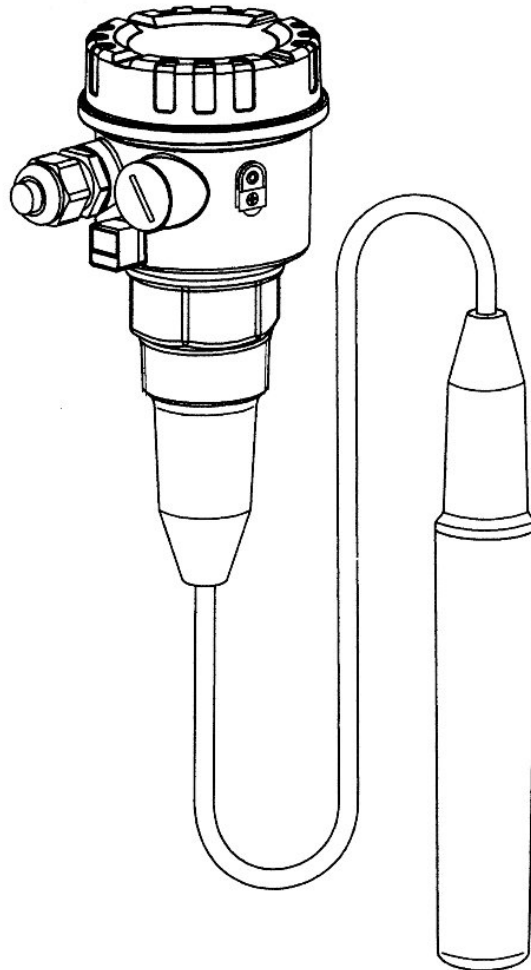

This filling level sensor is used for limit level detection in light bulk materials, e.g. crop, wheat, milk powder, mixed feed, cement, chalk or hard plaster.

Areas of Application

- Easy installation; you can start operating without calibration
- Integrated, active beginning compensation, thereby exact switching point also at heavy crust building on the sensor and high operational safety.
- No abrasion, long durability, maintenance-free.
- Various electronic applications, optimal adjustment to the system control.
- Rope sensor can be shortened, thus optimal adjustment to the metering point in the silo and easy storage.

Details / Explanation

- Polyester, IP 66

Body Finish

Installation

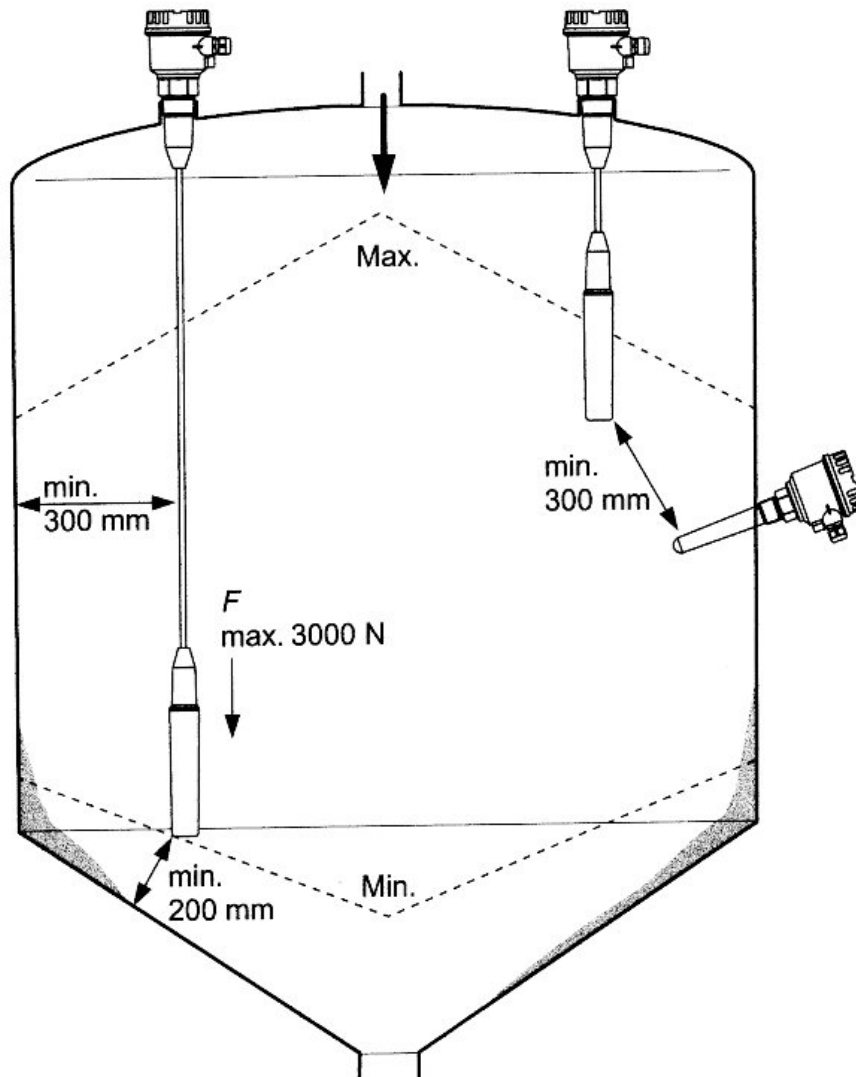

When calculating the optimal wire length, the angle of driving slope of the angle of repose or the haul-off hopper has to be considered.

Pay attention that enough space is left to feed materials and to the next sensor. The installation area must not be in the centre of the drain outlet cone. Instead there should be a good distance to the silo wall and to the material beginning on the silo wall respectively.

A metal plate mounted to the end part of the sensor, the isolation and the environment (e.g. the silo wall) form both electrodes of a condenser. If bulk cargo covers or releases the sensor, the limit switch of capacity and filling level shifts.

Functioning

The filling level limit switch recognizes crust building on the sensor and compensates the influence so that the shift point is always kept at exactly the same levels. The execution of the beginning compensation is dependent on the thickness of the crust on the sensor as well as the conductivity of the sensor pad and the sensitivity settings made electronically. This setting is alternately adjusted so that it switches precisely in most of the cases. Another way to adjust sensitivity is to change the multipolar switch on the electronic application. This is only required when heavy crust builds on the sensor or at very low relative permittivity ϵ_r of the bulk material. A correlation between relative permittivity ϵ_r and bulk density ρ of the bulking material can be recognized, but this correlation varies depending on the bulk material.

Scale drawing

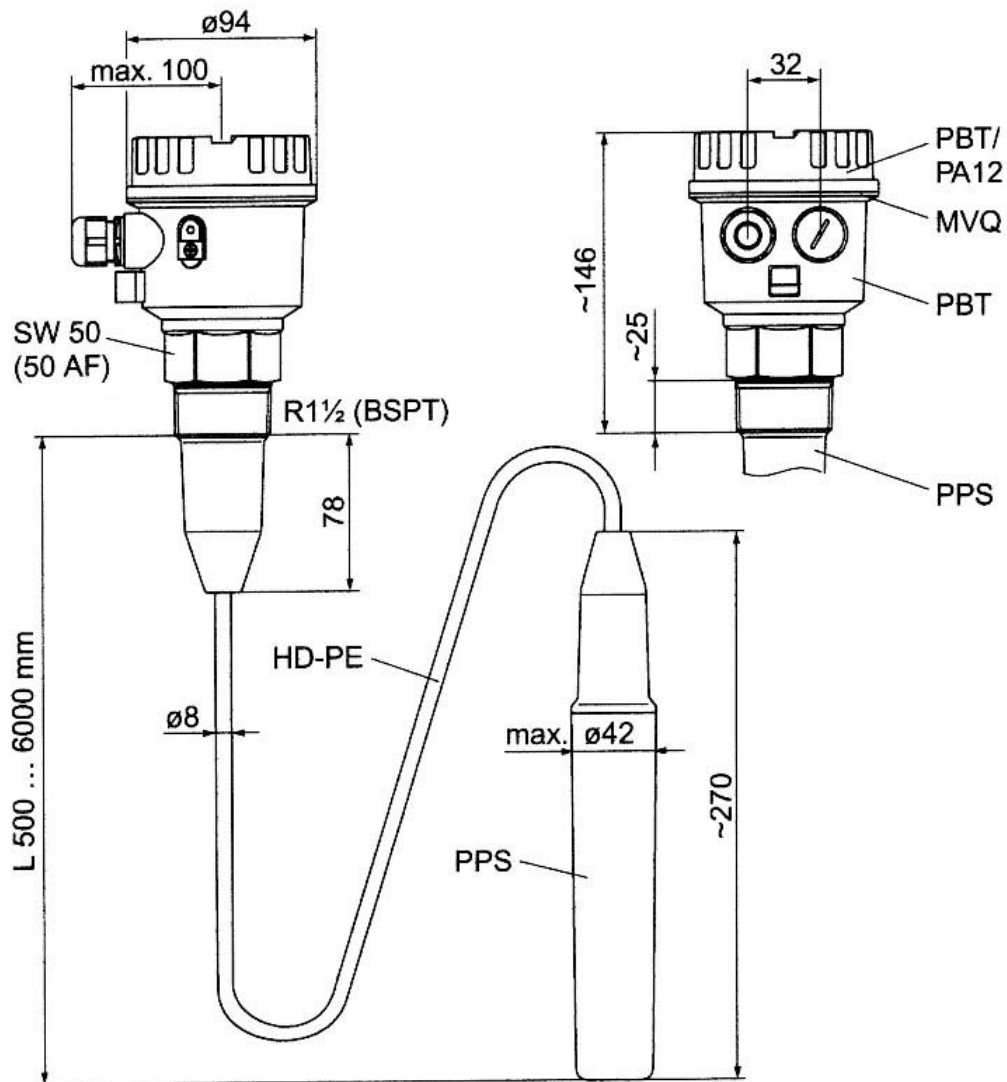

Tolerance of sensor depending on its length:

Length of Sensor L	Tolerance
up to 1000 mm	+0, -10 mm
up to 3000 mm	+0, -20 mm
up to 6000 mm	+0, -30 mm

Technical Data

Capacitive filling level limit detection	
Functioning	Capacitive
System structure	Compact device with sensor on rope, binary signal transmission.
Metering range	$\epsilon_r \geq 1,5$
Electronic application	With continuous current PNP-transistor exit, with continuous current/ alternating current relay output.
Output signal	Switch PNP: I_{max} 200 mA, overload / short-circuit protection, residual voltage on the transistor at $I_{max} < 2,9$ V. Contact change switch, potential-free: $U_{\sim max}$ 253 V, $I_{\sim max}$ 4 A $P_{\sim max}$ 1000 VA, $\cos \varphi = 1$ $P_{\sim max}$ 500 VA, $\cos \varphi > 0,7$ $I_{_ max}$ 4 A, bis $U_{_}$ 30 V $I_{_ max}$ 0,2 A, bis $U_{_}$ 235 V
Response time	At covering or release 0,8 s
Precision of measurements (for plastic container) at: Temperature T 23 °C Measuring material temperature 23 °C Measuring pressure $p_e = 0$ bar. Measuring material: Relative permittivity $\epsilon_r = 2,6$ Conductivity $< 1 \mu S$, setting sensitivity switch: C	Hysteresis: Vertical 5 mm Shift point: Vertical, 35 mm above sensor end Rising action: After max. 2 s correct shift setting Long-time drift: Vertical 6 mm Influence of measuring temperature: Depending on the filling material
Ambient temperature	-20 °C ...+70 °C, (...+60 °C dust ex-version)
Type of protection (body)	IP 66
Measuring material temperature	-20 °C ...+70 °C
Measuring material pressure limit	-1...+6 bar
Piled density of measuring material	min.200 g/l, $\epsilon_r \geq 1,6$
Grain size of measuring material	max. 30 mm
Process connection	Thread R 1 ½ after DIN 2999 BSPT.
Electrical connection	Screw clamp connection: For cord max. 1,5 mm ² . For wire max. 2,5 mm ² .
Operating display surface	Switch on the electronic application: Shift between min.- and max. security. Adjustment of sensitivity (dependent from relative permittivity ϵ_r and crust building). Normally, an adjustment of sensitivity is not necessary.

Article number

Capacitive filling level limit detection	
	Article number
	731 10 098